

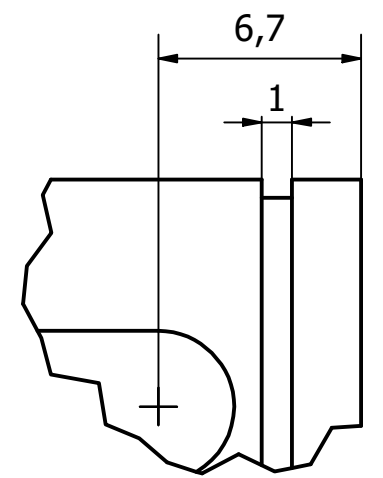

A-A (2 : 1)

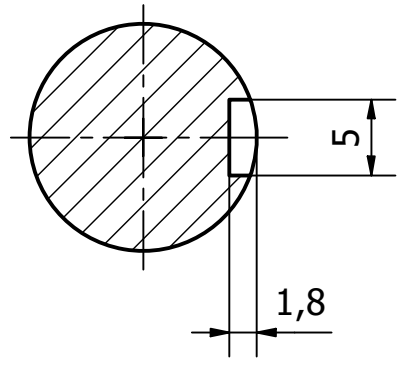

B (4 : 1)

 UNIVERSIDAD DE AMÉRICA		Facultad de ingeniería Ingeniería mecánica	
	DIBUJÓ	REVISÓ	APROBÓ
NOMBRE	L. Bautista - S. Pita		
FECHA	4/23/2021		
FIRMA			
ESCALA	DIM. EN	TOLERANCIAS	SISTEMA
2 : 1	mm	LINEAL: ± 0.1 ANGULAR: ± 0.5°	A4
MATERIAL	TRATAMIENTO		ACABADO SUPERFICIAL
Acero AISI 1020 107 LC			
DESCRIPCIÓN			PLANO
Máquina recolectora de mango - 20103 Eje Tornillo			21 / 43