

CORTE A-A

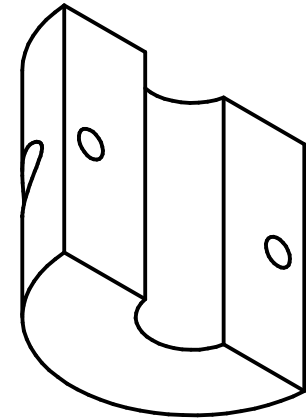

11	ANILLO PÉNDULO SUPERIOR	TOLERANCIAS $\pm 0,5$	1	AI SI 1040
ITEM	DESIGNACIÓN Y OBSERVACIONES	DIMENSIONES	CANTIDAD	MATERIAL

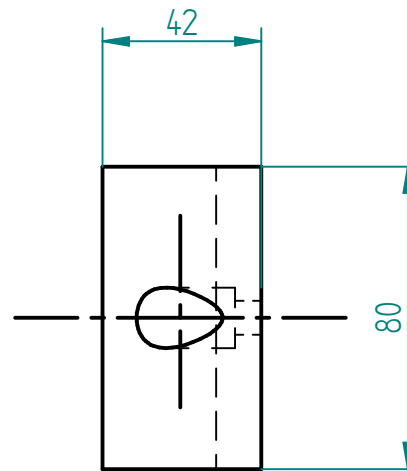
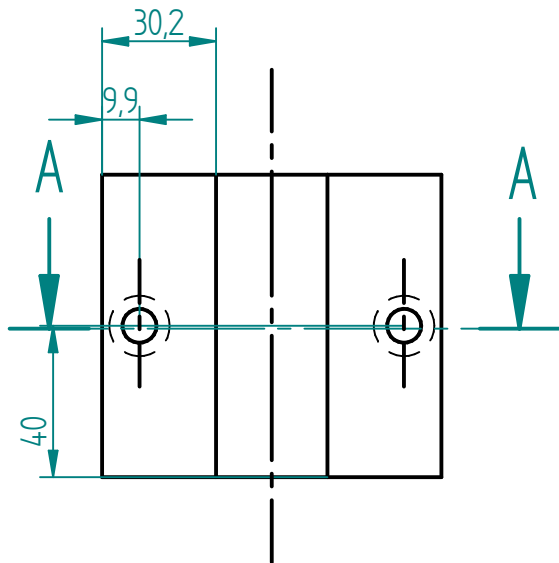

FUNDACIÓN UNIVERSIDAD DE AMÉRICA
FACULTAD DE INGENIERIAS
Programa de Ingeniería Mecánica

DISEÑO DE UNA MÁQUINA PARA ENSAYOS DE IMPACTO

ANILLO PÉNDULO SUPERIOR

ELABORADO POR: JOSE L. ORJUELA - JUAN S. HERRERA

FECHA: 1/10/2018

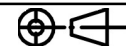

ESCALA: 1:2

PLANO N°: 15/40