

CORTE B-B

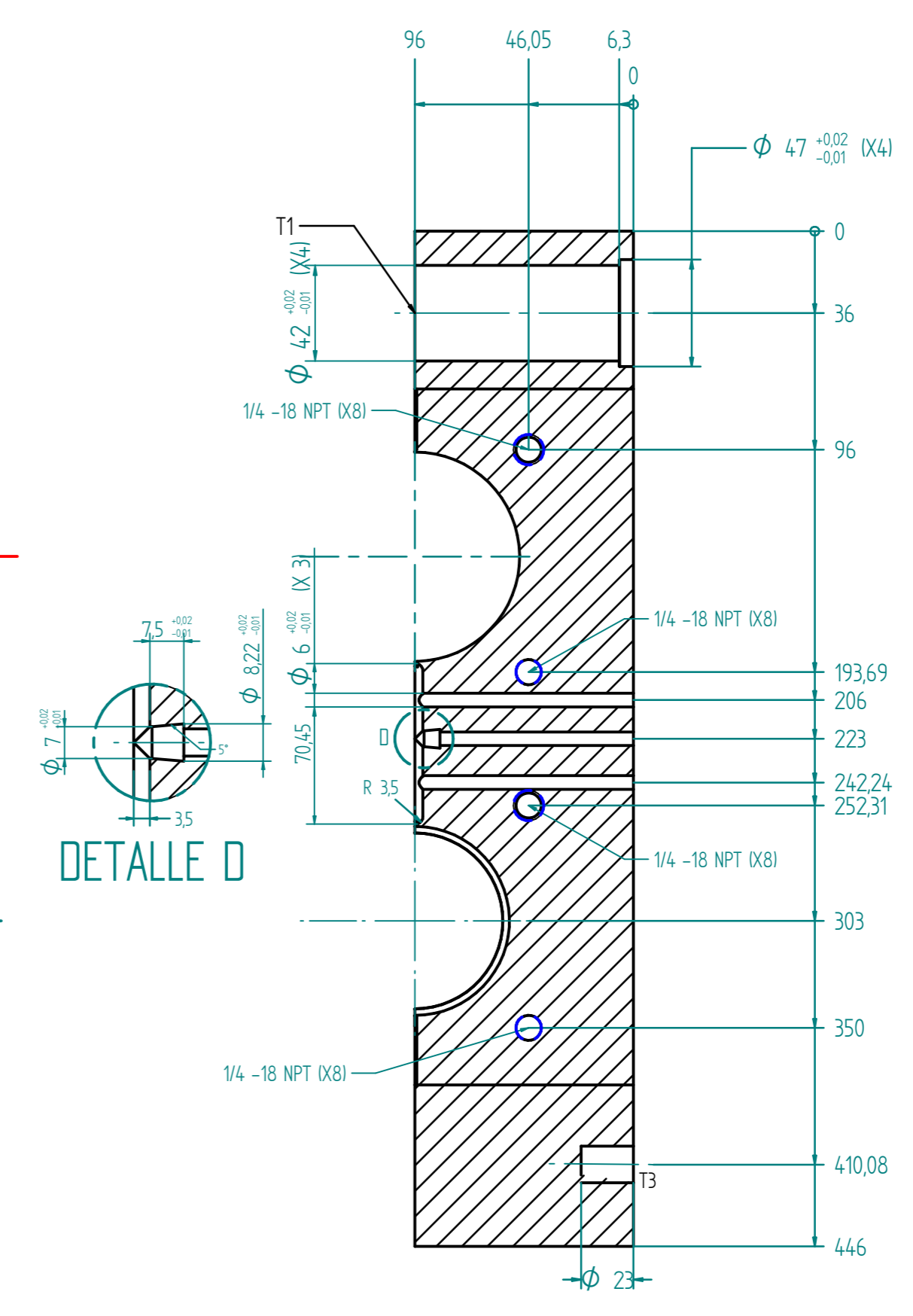

CORTE A-A

CORTE C-C

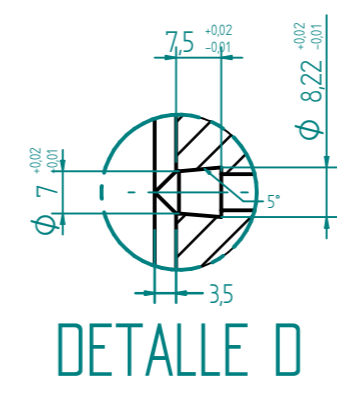
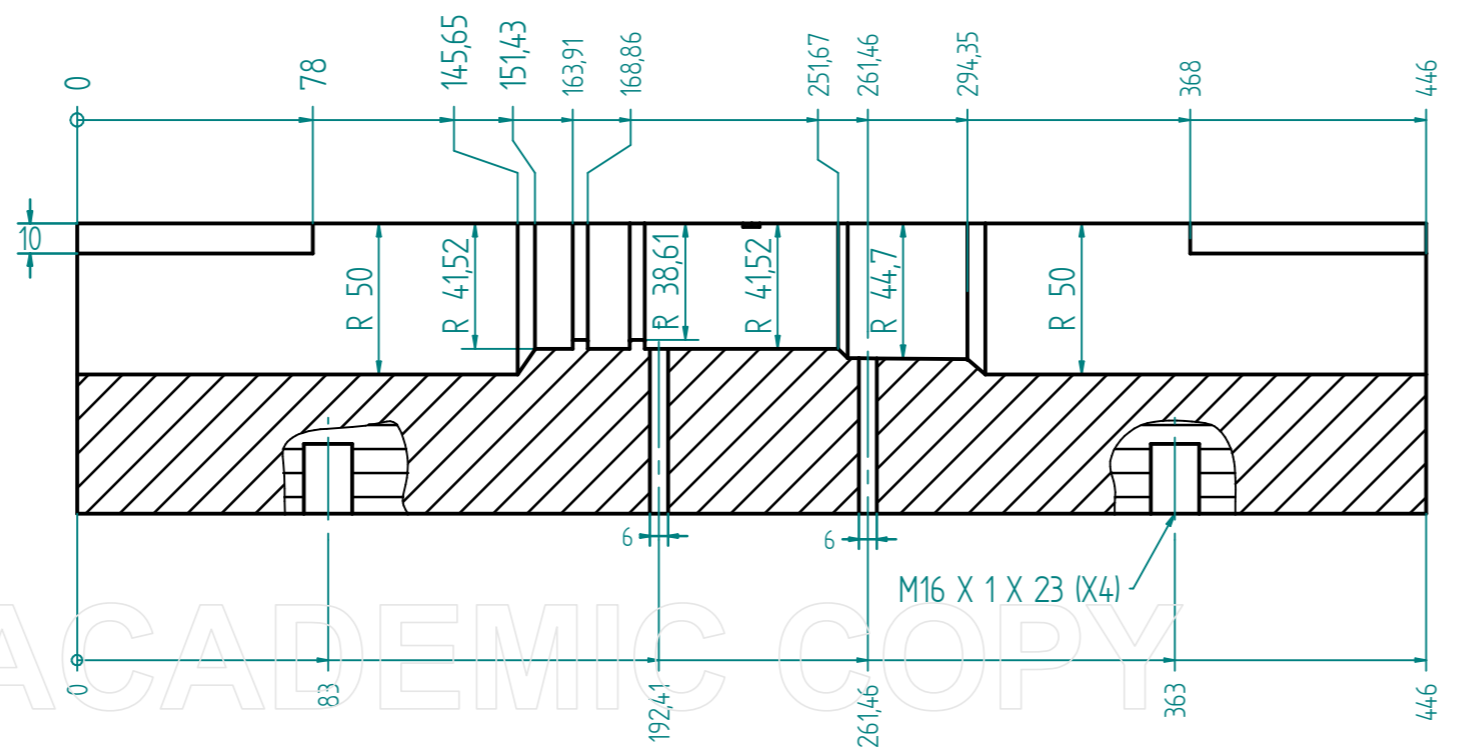

DETALLE D

DETALLES	
DESCRIPCION	REFERENCIA
T1	M 42 $\pm 0,02$ (X4)
T2	Ø 42 $\pm 0,02$ (X4)
T3	M16 X 0,5 (X4)

		FACULTAD DE INGENIERÍAS PROGRAMA INGENIERÍA MECÁNICA ASIGNATURA TRABAJO DE GRADO	
NOMBRE	ISABELA ROBLES HAMÓN	ELIMINAR ARISTAS VIVAS Y REBABAS	
NOMBRE	JUAN DIEGO PARRA	NO MEDIR SOBRE EL DIBUJO	
MATERIAL	ACERO INOXIDABLE AISI 410	TRATAMIENTO	TEMPLE
ESCALA:	1:1,25	DESCRIPCION	PLACA CAVIDADE MOVIL 446X446X96
CANTIDAD	1	CÓDIGO DE PLANO	13